

# IoT Network of Sensor Array for Intrusion Detection and Diagnosis of Electrical Systems

Andani Achmad<sup>a</sup>, Intan Sari Areni<sup>a</sup>, Elyas Palantei<sup>a</sup>, Andini Dani Achmad<sup>a</sup>, Muliadi<sup>b,\*</sup>

<sup>a</sup> Department of Electrical Engineering, Universitas Hasanuddin, Jl. Poros Malino km.6, Gowa, 92171, Indonesia

<sup>b</sup> Department of Electrical Education Engineering, Universitas Negeri Makassar, Jl. A.P.Pt. Rani, Makassar, 90224, Indonesia

Corresponding author: \*andani@unhas.ac.id

**Abstract**—Modern buildings consist of various equipment, including heating, ventilation, air conditioning (HVAC), and lighting. All equipment can be monitored and managed by the building management system. All of these components can be damaged due to prolonged use, misconfiguration, and network connection problems. Equipment breakdown affects maintenance costs and, in particular, energy efficiency. This study aims to develop a monitoring system of the current consumption of lighting (lamps) by light detection and current consumption of air conditioning (AC) by room temperature detection using Internet of Things (IoT) implementation. Hardware design consists of a power supply circuit, installing an ACS 712 current sensor, LDR sensor, the temperature sensor of DHT22, and thermal sensor of LM35. While the software design consists of a diagram flow for the current sensor, light sensor, temperature sensor reading program, program on the display board, and a web server design. The detection of current, lamplight, room temperature, and thermal cable is carried out to determine errors that occur in electrical equipment. Monitoring the consumption of lighting flows by detecting lamp light and air conditioning current consumption by detecting room temperature is done through the Firebase web server using a computer or smartphone. The results showed that the built system could monitor current consumption, detect lamplight, and detect room temperature in real-time. This system can be used to detect faulty electrical equipment and determine its position so that repairs can be carried out immediately. However, the type of damage has not been identified.

**Keywords**— IoT; sensor array; monitoring system; fault detection; web-based system.

Manuscript received 5 Nov. 2020; revised 17 Mar. 2021; accepted 23 Apr. 2021. Date of publication 30 Apr. 2022.  
IJASEIT is licensed under a Creative Commons Attribution-Share Alike 4.0 International License.



## I. INTRODUCTION

The concept of energy security has become a major challenge for sustainable economic development worldwide today [1]. According to the International Energy Agency, global electricity demand is expected to increase by more than two-thirds by 2035 [2]. In Indonesia, electricity demand continues to increase every year in line with the increase in national economic growth. The economy and prosperity of a region can increase after electrification. Indonesia's electrification ratio in 2018 has reached 98.05% [3], [4].

Excessive use of electricity is one of the problems faced by several countries in the world to maintain the availability of electrical energy in the future [5], [6]. The global consumption of electrical energy in 2018 has reached 23,398 TWh, an increase of 912 TWh from 2017 with a value of 22,486 TWh of electricity consumption [7]. Electrical problems are not only due to excessive use, but several other factors can harm the community, such as overheating electric

cables that trigger a fire disaster [8] [9] and unstable values of voltage and electric current, which can cause damage to electronic devices [10], [11].

The development of information technology in the field of the Internet of Things which emphasizes machine to machine (M2M) communication [12]–[14] and real-time remote control and surveillance [15]–[20] provide innovative solutions to problems in various fields of life [21]–[25]. One of them is the problem of electrical energy, such as wasteful electrical energy consumption [26], [27], late fault detection, or even non-existent and unstable currents [10], [28]. This problem can be solved by developing a real-time monitoring system for electricity usage.

Several researchers have carried out several studies related to the electricity use monitoring system. Santos and Ferreira [29] developed a monitoring system for electrical energy consumption and detected energy waste using LoRa Communication. Zhaou *et al.* [30] built an embedded device-based electrical energy monitoring system using Raspberry Pi and FPGA. Hamied *et al.* [31] developed a website

application for monitoring electrical photovoltaic (PV) arrays of current and voltage, air temperature, and solar irradiance online. Balamurugan and Saravanakamalam [32] developed an energy monitoring system that measures power, voltage, amperage, and energy consumption via the internet using WiFi communication. Soh *et al.* [33] built an energy consumption monitoring system equipped with an alert system that is active if the energy consumption limit has been exceeded using the Ubidots Cloud Service. Hartman *et al.* [34] built a monitoring system for energy consumption in Air Conditioning Units (AC) through Wi-Fi Communication using Raspberry Pi Zero W. Haithem *et al.* [35] built a Heating, Ventilation, and Air Conditioning (HVAC) System using Machine to Machine (M2M) Communication resulting in energy savings in the use of air conditioning with an embedded test model on two ACs by providing auto-control for managing energy in order to save energy.

This study builds an electrical monitoring system that monitors the indoor environment as an integrated system. The system built has four main features. First, the system can detect the number of light incidents in a room connected to a light switching system to efficiently use electrical energy. Second, the system can monitor the temperature value of a room that is connected to the Air Conditioner (AC) controller. Third, the system can monitor the temperature value of the electrical cable equipped with an alert system if the temperature exceeds the limit to prevent overheating of the cable, which can cause a fire disaster. Fourth, the system can monitor the value of the electric current connected to the system in the form of panel current, lamp current, AC current, and socket current in real-time. The system built can increase the efficiency of the use of electrical energy and provide early

detection of electrical system disturbances. In addition, this system can solve problems in the use of electric power.

This paper is structured as follows. Section 1 discusses the background of the research, section 2 explains the proposed system, section 3 discusses the results and analysis, and section 4 concludes all research results.

## II. MATERIAL AND METHOD

Lighting energy monitoring system (lamp) is done by light detection and air conditioning (AC) with room temperature detection. Designing an electrical system monitoring and detection system involves designing a radio and telecommunications laboratory prototype, designing hardware, and designing software. The system was tested in one room with lighting equipment (lights) and air conditioning (AC). The trial stage is to monitor the current consumption of the lamp by detecting the light and monitoring the current consumption of the air conditioning with room temperature detection.

The prototype design of the Radio and Microwave Telecommunication Laboratory consists of nine rooms, namely Radio and Microwave Telecommunications Laboratory Room (R 5.1), the AP ROOM 2 (R 5.2), the AP Room 1 (R 5.3), the Professor Room (R 5.4), the Assistant Room (R 5.5), Meeting Room (R 5.6), Student Room (R 5.7), Laboratory Assistant Room (R 5.8), Computer and PABC Room (R 5.10) and corridors (R 5.9). Each room is equipped with lighting equipment, air conditioning, and computers, except for the Radio and Microwave Telecommunication Laboratory Room which is only equipped with lighting and practical equipment as shown in Fig. 1.

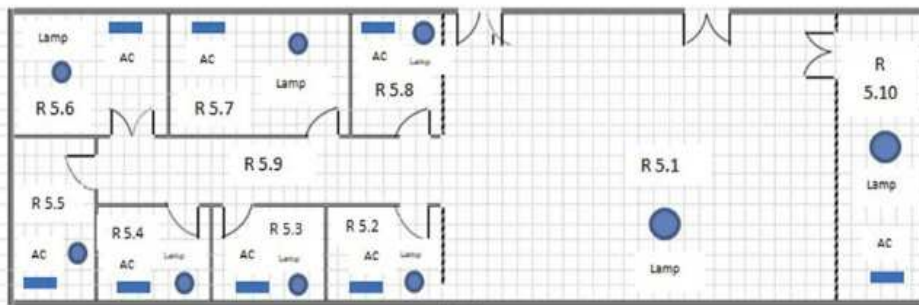

Fig. 1 Floor plan of Radio and Microwave Telecommunication Laboratory

Fig. 1 show the floor plan of The Radio and Microwave Telecommunication Laboratory. Hardware design consists of designing a power supply, installing an ACS 712 current sensor, installing a LDR (Photosensitive light sensor), and

installing a temperature sensor DHT22. Power supply with an output of +5V serves as a voltage source for the Wemos D1R1 module and the ESP8266 module. The series image is as shown in Fig. 2.

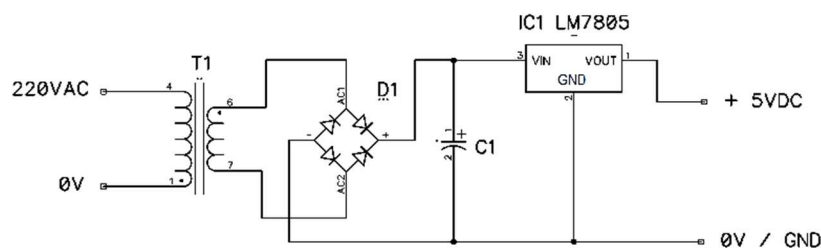

Fig. 2 Power supply circuit

The ACS712 current sensor consists of 3 pins, namely VCC, GND and OUT on the Wemos D1 board ESP8266 module. VCC and GND. VCC and GND are connected to a +5V voltage and ground power supply. The OUT pin of current sensor is connected to pin A0 on the Wemos D1 module on the ESP8266 board. There are 4 pins optical LDR lights for photosensitive light sensor consisting of VCC, GND, D0, and A0 on the Wemos D1 board ESP8266 module. VCC

and GND are connected to a +5V power supply, A0 is connected to pin D8. While DHT22 temperature sensor consists of 3 pins, namely +5VCC, GND, and Data on the Wemos D1 module on the ESP8266 board. The +5VCC and GND pins are connected to the power supply, and the data are connected to the D2 pins of the Wemos D1 module on the ESP8266 board. The installation of the ACS712, LDR, thermal sensor, and DHT22 is shown in Fig. 3.

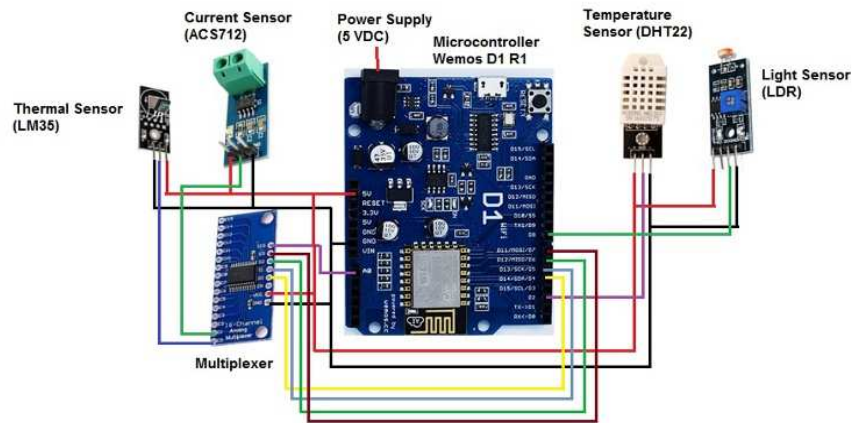

Fig. 3 Installation of the ACS712 current sensor, light sensor, Thermal sensor and DHT22 temperature sensor on the Wemos D1 board ESP8266 module

The software design consists of several stages, namely making a flowchart monitoring system for current, light, temperature, current reading program, light sensor reading program, and temperature sensor reading program, display program on the display board and web server design for communication between Wemos R1 board ESP8266 and the computer device or smartphone using the internet network. Flowchart of lighting energy monitoring system (lamp) with light detection and air conditioning (AC) with room temperature detection as shown in Fig. 4.

account that has been registered with the Firebase web service, open [firebase.google.com](https://firebase.google.com), click Go to console, select monitoring lab-radio-Telkom. The next step is to select develop so that the develop menu appears, then select the database so that the Lab-Radio-Telkom monitoring will appear. The sensor reading program, the display program on the board, and the webserver design for communication between the Wemos D1 ESP8266 board and a computer or smartphone using the internet system are described as follows.

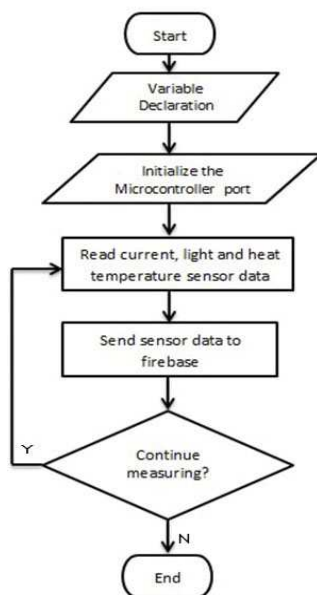

Fig. 4 Flowchart of lighting energy monitoring system (lamp) with light detection and air conditioning (AC) with room temperature detection

Testing the monitoring system can be conducted using the Firebase web service. The first step is to log in with a Google

```
#include <ESP8266WiFi.h>
#include <FirebaseArduino.h>
#include <SPL.h>
#include <Wire.h>
#include <SimpleDHT.h>
#include <ACS712.h>

// Set to run firebase and wifi
#define FIREBASE_HOST "monitoring-and-control-ab.firebaseio.com"
#define FIREBASE_AUTH "0qYhJouHUFGRiYxKtVktMqluIeBr7DiAwkX1uOe"
#define WIFI_SSID "Muliandira"
#define WIFI_PASSWORD "R4h4s14@"

//Temperature sensor DHT22
int pinDHT22 = D8;
SimpleDHT22 dht22(pinDHT22);
float temperature = 0;
float humidity = 0;
int err = SimpleDHTErrSuccess;

//Light sensor LDR, Temp sensor LM35
byte analogPin = A0;
int adc = 0;
float tempLM35 = 00;

//Current sensor ACS712
ACS712 ACS(A0, 5, 1023, 185); // max. 5A = 185 float mA ;
float current ;
void setup() {
//Switch Multiplexer
pinMode (D4,OUTPUT);
pinMode (D5,OUTPUT);
```

```

pinMode (D6,OUTPUT);
Serial.begin(9600);
//Firebase controlling
pinMode (D2, OUTPUT); //panel
pinMode (D3, OUTPUT); //penyejuk rusangan
pinMode (D9, OUTPUT); //penerangan
pinMode (D10, OUTPUT); //stok kontak
//Buzzer bip
pinMode (D11, OUTPUT);
// Connect to wifi.
WiFi.begin(WIFI_SSID, WIFI_PASSWORD);
while (WiFi.status() != WL_CONNECTED) {
  Serial.println("Connected");
  delay(500);}
//Connect to firebase
Firebase.begin(FIREBASE_HOST, FIREBASE_AUTH);
Firebase.set("Telecommunication Radio & Microwave Laboratory
/Computer & PABX Room /Panel Switch",1);
Firebase.set("Telecommunication Radio & Microwave Laboratory
/Computer & PABX Room /Air Conditioning Switch",1);
Firebase.set("Telecommunication Radio & Microwave Laboratory
/Computer & PABX Room /Lamp Switch",1);
Firebase.set("Telecommunication Radio & Microwave Laboratory
/Computer & PABX Room /Socket Switch",1);
}
int swpanel;
int swpenyekruangan;
int swpenerangan;
int swstokkontak;
void loop() {
digitalWrite (D11,HIGH); delay(100); digitalWrite (D11,LOW);
  delay(100);
panelACS712(); //Current sensor panel processing
airconditionerACS712(); //Current sensor air conditioner processing
lampACS712(); //Current sensor lamp processing
stokcontactACS712(); //Current sensor stok contact processing
tempDHT22sensor(); //Temp sensor DHT22 processing
lightsensor(); //Light sensor LDR processing
tempLM35sensor(); //Temp sensor LM35 processing
//Controller
swpanel = Firebase.getInt("Telecommunication Radio & Microwave
Laboratory /Computer & PABX Room /Panel Switch");
if (swpanel==1) {Serial.println("Panel ON"); digitalWrite(D2,LOW);}
if (swpanel==0) {Serial.println("Panel OFF"); digitalWrite(D2,HIGH); }
swpenyekruangan = Firebase.getInt("Telecommunication Radio &
Microwave Laboratory /Computer & PABX Room /Air
Conditioning Switch");
if (swpenyekruangan==1) {Serial.println("Penyejuk Ruang ON");
  digitalWrite(D3,LOW);}
if (swpenyekruangan==0) {Serial.println("Penyejuk Ruang OFF");
  digitalWrite(D3,HIGH); }
swpenerangan = Firebase.getInt("Telecommunication Radio &
Microwave Laboratory /Computer & PABX Room /Lamp
Switch");
if (swpenerangan==1) {Serial.println("Penerangan ON");
  digitalWrite(D9,LOW); }
if (swpenerangan==0) {Serial.println("Penerangan OFF");
  digitalWrite(D9,HIGH);}
swstokkontak = Firebase.getInt("Telecommunication Radio &
Microwave Laboratory /Computer & PABX Room /Socket
Switch");
if (swstokkontak==1) {Serial.println("Stok Kontak ON");
  digitalWrite(D10,LOW); }
if (swstokkontak==0) {Serial.println("Stok Kontak OFF");
  digitalWrite(D10,HIGH); }
//delay(60000);
}
//Collection void for system.
void panelACS712(){
digitalWrite(D4,LOW);
digitalWrite(D5,LOW);
digitalWrite(D6,LOW);
mA = ACS.mA_AC();
current = (mA / 1000)-0.05;
if (current>=0){String panel = String (current,2)+ String (" A");
  Firebase.setString ("Telecommunication Radio & Microwave
Laboratory /Computer & PABX Room /Panel Switch /Panel
Current", panel); delay(10);}
else {Firebase.setString ("Telecommunication Radio & Microwave
Laboratory /Computer & PABX Room /Panel Switch /Panel
Current", "0 A"); delay(10);}}
void airconditionerACS712(){
digitalWrite(D4,HIGH);
digitalWrite(D5,LOW);
digitalWrite(D6,LOW);
mA = ACS.mA_AC();
current = (mA / 1000)-0.05;
if (current>=0){String airconditionercurrent = String (current,2)+
  String (" A");
  Firebase.setString ("Telecommunication Radio & Microwave
Laboratory /Computer & PABX Room /Air Conditioning Switch
/Air Conditioning Current", airconditionercurrent); delay(10);}
else {Firebase.setString ("Telecommunication Radio & Microwave
Laboratory /Computer & PABX Room /Air Conditioning Switch
/Air Conditioning Current", "0 A"); delay(10);}}
void lampACS712(){
digitalWrite(D4,LOW);
digitalWrite(D5,HIGH);
digitalWrite(D6,LOW);
mA = ACS.mA_AC();
current = (mA / 1000)-0.05;
if (current>=0){String lamp = String (current,2)+ String (" A");
  Firebase.setString ("Telecommunication Radio & Microwave
Laboratory /Computer & PABX Room /Lamp Switch /Lamp
Current", lamp); delay(10);}
else {Firebase.setString ("Telecommunication Radio & Microwave
Laboratory /Computer & PABX Room /Lamp Switch /Lamp
Current", "0 A"); delay(10);}}
void stokcontactACS712(){
digitalWrite(D4,HIGH);
digitalWrite(D5,HIGH);
digitalWrite(D6,LOW);
mA = ACS.mA_AC();
current = (mA / 1000)-0.05;
if (current>=0){String stokcontact = String (current,2)+ String (" A");
  Firebase.setString ("Telecommunication Radio & Microwave
Laboratory /Computer & PABX Room /Socket Switch /Socket
Current", stokcontact); delay(10);}
else {Firebase.setString ("Telecommunication Radio & Microwave
Laboratory /Computer & PABX Room /Socket Switch /Socket
Current", "0 A"); delay(10);}}
void tempDHT22sensor(){
//MuxTempDHT22();
if ((err = dht22.read2(&temperature, &humidity, NULL)) !=
  SimpleDHTErrSuccess){return;}
String DHT22Temp = String (temperature) + String (" °C");
Firebase.setString("Telecommunication Radio & Microwave
Laboratory /Computer & PABX Room /Air Conditioning Switch
/Temperature Sensor Value", DHT22Temp); delay(10);}
void lightsensor(){
digitalWrite(D4,LOW);
digitalWrite(D5,LOW);
digitalWrite(D6,HIGH);
adc = analogRead(analogPin);
if (adc <500){Firebase.setString ("Telecommunication Radio &
Microwave Laboratory /Computer & PABX Room /Lamp Switch
/Light Sensor Condition", "Light");delay(10);}
else {Firebase.setString ("Telecommunication Radio & Microwave
Laboratory /Computer & PABX Room /Lamp Switch /Light
Sensor Condition", "No Light");delay(10);}}
void tempLM35sensor(){
digitalWrite(D4,HIGH);
digitalWrite(D5,LOW);
digitalWrite(D6,HIGH);
adc = analogRead(analogPin);
tempLM35 = (adc/3.222);
String tempLM35A= String (tempLM35) + String (" °C");
Firebase.setString ("Telecommunication Radio & Microwave
Laboratory /Computer & PABX Room /Socket Switch /Thermal
Sensor Value/Temperature",tempLM35A );delay(10);}

```

```

if (tempLM35 <=70){Firebase.setString ("Telecommunication Radio &
Microwave Laboratory /Computer & PABX Room /Socket
Switch /Socket Temperature/Condition", "Secure" );delay(10);}
else {Firebase.setString ("Telecommunication Radio & Microwave
Laboratory /Computer & PABX Room /Socket Switch /Socket
Temperature/Condition", "Warning");delay(10);}

```

### III. RESULTS AND DISCUSSION

The sensor module and controller module prototype to activate air conditioning (AC), lighting (lamps), and relays for electric socket are shown in Fig. 5 and Fig. 6, respectively.

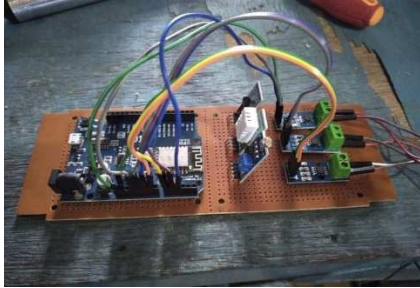

Fig. 5 The results of the installation of current sensors, light sensors, temperature sensors and thermal sensors

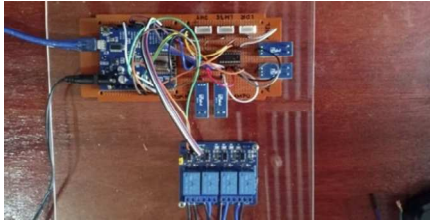

Fig. 6 Installation of a control system to activate the air conditioner (AC), lighting (lamp), and electric socket using a relay on the Wemos D1 module on board ESP8266

The results of the consumption monitoring of lighting currents (lamps) type LED with 55W power, current consumption of air conditioning (AC) with 330-Watt power of 1.6, consumption of electric socket currents connected to a personal computer (PC) with a power supply of 430 Watt and LCD monitor with 1.5A for 60 minutes using an ACS 712 current sensor is shown in Table 1.

TABLE I  
MONITORING RESULTS OF LIGHTING CURRENT CONSUMPTION (LAMP), ROOM (AC), ELECTRIC SOCKET CURRENT, AND PANEL CURRENT USING ACS712 CURRENT SENSOR

No.	Switch Condition				Time (Min)	Current Values of Sensor			
	SW 1	SW 2	SW 3	SW 4		Panel current (A)	Lamp Current (A)	AC Current (A)	Socket Current (A)
1	0	0	0	0	-	0	0	0	0
2	1	1	1	1	6'	2.50	0.28	1.47	0.69
3	1	1	1	1	12'	2.76	0.29	1.53	0.71
4	1	1	1	1	18'	2.58	0.24	1.50	0.68
5	1	1	1	1	24'	2.49	0.22	1.48	0.67
6	1	1	1	1	30'	2.53	0.25	1.52	0.65
7	1	1	1	1	36'	2.56	0.29	1.49	0.60
8	1	1	1	1	42'	0.90	0.22	0.13	0.59
9	1	1	1	1	48'	2.51	0.25	1.50	0.62
10	1	1	1	1	54'	2.65	0.29	1.52	0.69
11	1	1	1	1	60'	2.53	0.29	1.53	0.66

In the Switch Condition columns, 0 indicates the switch is off and 1 indicates the switch is on. The results of the measurements of the consumption of LED lighting (lamps)

with a power of 55W, the current consumption of air conditioning (AC) with a power of 330 watts with a current of 1.6 A, the current consumption of the electric socket connected to a personal computer (PC) with a power supply of 430W and LCD monitor with a current of 1.5 A for 60 minutes using a clamp meter is shown in Table 2. The results of monitoring room temperature using the DHT22 sensor, monitoring the thermal temperature or cable heat using the LM35 sensor, and monitoring the lighting conditions in the room using a light sensor for 60 minutes are shown in Table 3.

TABLE II  
MEASUREMENT RESULTS OF LIGHTING CURRENT CONSUMPTION (LAMP), ROOM (AC), ELECTRIC SOCKET CURRENT, AND PANEL CURRENT USING CLAMP METER

No.	Switchs Condition				Time (Min)	Current Values of Sensor			
	SW 1	SW 2	SW 3	SW 4		Panel current (A)	Lamp Current (A)	AC Current (A)	Socket Current (A)
1	0	0	0	0	-	0	0	0	0
2	1	1	1	1	6'	2.38	0.27	1.40	0.66
3	1	1	1	1	12'	2.62	0.28	1.45	0.67
4	1	1	1	1	18'	2.45	0.23	1.43	0.65
5	1	1	1	1	24'	2.37	0.21	1.41	0.64
6	1	1	1	1	30'	2.40	0.24	1.44	0.62
7	1	1	1	1	36'	2.43	0.28	1.42	0.57
8	1	1	1	1	42'	0.86	0.21	0.12	0.56
9	1	1	1	1	48'	2.38	0.24	1.43	0.59
10	1	1	1	1	54'	2.52	0.28	1.44	0.66
11	1	1	1	1	60'	2.40	0.28	1.45	0.63

TABLE III  
MONITORING RESULTS OF LIGHTING CONDITIONS, ROOM TEMPERATURE, AND THERMAL CABLE TEMPERATURE USING DHT22 AND LM35 LIGHT SENSORS

No.	Switchs Condition				Time (Min)	Light sensor cond.	Temperature Sensor Value (°C)	Thermal sensor value (°C)
	SW 1	SW 2	SW 3	SW 4				
1	0	0	0	0	-	Not Detect	28.30	29.50
2	1	1	1	1	6'	Detect	27.20	28.70
3	1	1	1	1	12'	Detect	24.70	26.40
4	1	1	1	1	18'	Detect	25.40	26.60
5	1	1	1	1	24'	Detect	22.90	24.40
6	1	1	1	1	30'	Detect	18.65	20.35
7	1	1	1	1	36'	Detect	18.10	19.30
8	1	1	1	1	42'	Detect	16.55	18.05
9	1	1	1	1	48'	Detect	21.70	23.40
10	1	1	1	1	54'	Detect	20.35	21.55
11	1	1	1	1	60'	Detect	19.10	20.60

The results show that the electrical panel energy monitoring system prototype, lighting (lamps) with light detection, air conditioning (AC) with room temperature detection, energy monitoring in an electric socket with cable thermal (heat) temperature detection was successfully designed and successfully accessed through computer or smartphone using the Firebase web service application. For current monitoring in Table 1, it shows that the average current consumption is 0.26 A. As long as a current flowing in the lighting device (lamp), the light will be detected. If the current is flowing, the room temperature has decreased significantly from the initial

temperature of 28.30°C after 60 minutes to 19.10°C. The electric socket is connected to a personal computer (PC) with a power supply of 430W and an LCD monitor with a current of 1.5A and cable thermal temperature detection (heat). The average current consumption is 0.66A for 60 minutes, and the thermal (heat) temperature detection is an average of 25.9°C for 60 minutes. The thermal (heat) temperature of the cable is still in safe condition. It indicated the current, temperature, and heat monitoring system work properly. The results obtained were validated with a clamp meter with an average current difference of 0.04A or around 5.26%.

#### IV. CONCLUSION

The lighting (lamps) monitoring system with light detection and air conditioning (AC) with room temperature detection can be accessed via computer or smartphone using the Firebase web service application. Detection of light using a light sensor indicates that the lighting (lamps) in the room is well monitored. The detection of room temperature that has decreased during monitoring shows that the air conditioning (AC) condition in the room is well monitored. The cable's thermal (heat) temperature detection still shows a value in safe conditions, which is around 25.6°C. Research development can be carried out by optimizing sensors in detecting errors that often occur in electrical equipment or electrical systems with notifications via Android applications on smartphones such as Telegrams.

#### ACKNOWLEDGMENT

Universitas Hasanuddin funds this research through LPPM in PDU scheme 2020.

#### REFERENCES

- [1] F. Harkouss, F. Fardoun, and P. H. Biwolé, "Multi-objective optimization methodology for net zero energy buildings," *J. Build. Eng.*, vol. 16, no. December 2017, pp. 57–71, 2018, doi: 10.1016/j.jobe.2017.12.003.
- [2] M. A. Hannan *et al.*, "A review of internet of energy based building energy management systems: Issues and recommendations," *IEEE Access*, vol. 6, no. c, pp. 38997–39014, 2018, doi: 10.1109/ACCESS.2018.2852811.
- [3] A. I. Malakani, D. Handoko Arthanto, B. G. Dwi Wicaksono, and A. Purwadi, "Study and Design of Off-Grid PV Power System in Pirien, Asmat Regency, Papua Province using MATLAB/SIMULINK," *Proc. 2nd Int. Conf. High Volt. Eng. Power Syst. Towar. Sustain. Reliab. Power Deliv. ICHVEPS 2019*, pp. 339–343, 2019, doi: 10.1109/ICHVEPS47643.2019.9011048.
- [4] K. Chooruang, "Design of an IoT Energy Monitoring System," *2018 16th Int. Conf. ICT Knowl. Eng.*, pp. 1–4, 2018, doi: 10.1109/ICTKE.2018.8612412.
- [5] Electrical Energy Waste And Misuse At Home, Westline Electrical, [tps://www.electricianinperth.com.au/blog/how-electrical-energy-loss-and-misuse-is-wasted-at-home/\(accessed Mar. 25, 2021\)](https://www.electricianinperth.com.au/blog/how-electrical-energy-loss-and-misuse-is-wasted-at-home/(accessed Mar. 25, 2021)).
- [6] R. Gray, "'The biggest energy challenges facing humanity,'" [https://www.bbc.com/future/article/20170313-the-biggest-energy-challenges-facing-humanity \(accessed Mar. 25, 2021\)](https://www.bbc.com/future/article/20170313-the-biggest-energy-challenges-facing-humanity (accessed Mar. 25, 2021)).
- [7] N. Sonnichen, "'Net consumption of electricity worldwide in select years from 1980 to 2018' Statista Feb. 04, 2021,'" [https://www.statista.com/statistics/280704/world-power-consumption/\(accessed Mar. 25, 2021\)](https://www.statista.com/statistics/280704/world-power-consumption/(accessed Mar. 25, 2021)).
- [8] Korinek, C., "The basics of electrical overheating" Res Gate, p. 108, 2009," [https://www.ecmweb.com/maintenance-repair-operations/article/20890352/the-basics-of-electrical-overheating \(accessed Mar. 25, 2021\)](https://www.ecmweb.com/maintenance-repair-operations/article/20890352/the-basics-of-electrical-overheating (accessed Mar. 25, 2021)).
- [9] 5 common causes of electrical fires, FireRescue1, <https://www.firerescue1.com/fire-products/firefightingtools/articles/5-common-causes-of-electrical-fires-olFt6TUMOsWg7re2/ Accessed Mar. 25, 2021.>
- [10] R. Azly, "Causes of Unstable (Fluctuate) electricity home and what are the solution," [https://diary-of-electric.blogspot.com/2018/10/causes-of-unstable-electricity-at-home-and-what-are-the-solutions.html \(Accessed Mar. 25, \(accessed Mar. 25, 2021\) 2021](https://diary-of-electric.blogspot.com/2018/10/causes-of-unstable-electricity-at-home-and-what-are-the-solutions.html (Accessed Mar. 25, (accessed Mar. 25, 2021) 2021).
- [11] The Effects of Power Outages on Computers & Electronics - Penny Electric, Penny Electric - Las Vegas Electrician & Electrical Service, Oct. 17, 20118," [https://pennyelectric.com/blog/the-effects-of-power-outages-on-computers-electronics/\(Accessed Mar. 25, 2021](https://pennyelectric.com/blog/the-effects-of-power-outages-on-computers-electronics/(Accessed Mar. 25, 2021).
- [12] S. N. Swain, R. Thakur, and S. R. M. Chebiyyam, "Coverage and Rate Analysis for Facilitating Machine-To-Machine Communication in LTE-A Networks Using Device-To-Device Communication," *IEEE Trans. Mob. Comput.*, vol. 16, no. 11, pp. 3014–3027, 2017, doi: 10.1109/TMC.2017.2684162.
- [13] C. Di, B. Zhang, Q. Liang, S. Li, and Y. Guo, "Learning Automata-Based Access Class Barring Scheme for Massive Random Access in Machine-to-Machine Communications," *IEEE Internet Things J.*, vol. 6, no. 4, pp. 6007–6017, 2019, doi: 10.1109/JIOT.2018.2867937.
- [14] Y. Wu, N. Zhang, and K. Rong, "Non-Orthogonal Random Access and Data Transmission Scheme for Machine-to-Machine Communications in Cellular Networks," *IEEE Access*, vol. 8, pp. 27687–27704, 2020, doi: 10.1109/ACCESS.2020.2972064.
- [15] A. Hendra, E. Palantei, Syafaruddin, M. S. Hadis, N. Zulkarnaim, and M. F. Mansyur, "Wireless Sensor Network Implementation for IoT-Based Environmental Security Monitoring," *IOP Conf. Ser. Mater. Sci. Eng.*, vol. 875, no. 1, 2020, doi: 10.1088/1757-899X/875/1/012093.
- [16] P. Verma and S. K. Sood, "Fog assisted-IoT enabled patient health monitoring in smart homes," *IEEE Internet Things J.*, vol. 5, no. 3, pp. 1789–1796, 2018, doi: 10.1109/JIOT.2018.2803201.
- [17] S. Du, B. Liu, H. Ma, G. Wu, and P. Wu, "IIOT-Based intelligent control and management system for motorcycle endurance test," *IEEE Access*, vol. 6, no. c, pp. 30567–30576, 2018, doi: 10.1109/ACCESS.2018.2841185.
- [18] X. Wang, C. Yang, and S. Mao, "Resilient Respiration Rate Monitoring with Realtime Bimodal CSI Data," *IEEE Sens. J.*, vol. 20, no. 17, pp. 10187–10198, 2020, doi: 10.1109/JSEN.2020.2989780.
- [19] C. Ai, F. H. Li, and K. Zhang, "Detecting isolate safe areas in wireless sensor monitoring systems," *Tsinghua Sci. Technol.*, vol. 22, no. 4, pp. 427–436, 2017, doi: 10.23919/TST.2017.7986945.
- [20] Z. Yi, B. Yang, W. Zhang, Y. Wu, and J. Liu, "Batteryless Tire Pressure Real-Time Monitoring System Driven by an Ultralow Frequency Piezoelectric Rotational Energy Harvester," *IEEE Trans. Ind. Electron.*, vol. 68, no. 4, pp. 3192–3201, 2021, doi: 10.1109/TIE.2020.2978727.
- [21] M. S. Hadis and E. Palantei, "Smart Lock System for Doors Using Bluetooth Technology," pp. 397–401, 2018.
- [22] N. Alshurafa, C. Sideris, M. Pourhomayoun, H. Kalantarian, M. Sarrafzadeh, and J. A. Eastwood, "Remote Health Monitoring Outcome Success Prediction Using Baseline and First Month Intervention Data," *IEEE J. Biomed. Heal. Informatics*, vol. 21, no. 2, pp. 507–514, 2017, doi: 10.1109/JBHI.2016.2518673.
- [23] I. A. Zualkernan, M. Rashid, R. Gupta, and M. Alikarar, "A Smart Home Energy Management System Using IoT and Big Data Analytics Approach," vol. 63, no. 4, pp. 426–434, 2017.
- [24] P. P. Ray, M. Mukherjee, and L. Shu, "Internet of Things for Disaster Management: State-of-the-Art and Prospects," *IEEE Access*, vol. 5, no. i, pp. 18818–18835, 2017, doi: 10.1109/ACCESS.2017.2752174.
- [25] K. Shafique, B. A. Khawaja, F. Sabir, S. Qazi, and M. Mustaqim, "Internet of things (IoT) for next-generation smart systems: A review of current challenges, future trends and prospects for emerging 5G-IoT Scenarios," *IEEE Access*, vol. 8, pp. 23022–23040, 2020, doi: 10.1109/ACCESS.2020.2970118.
- [26] Y. Sato, "Energy consumption: An environmental problem," *IEEEJ Trans. Electr. Electron. Eng.*, vol. 2, no. 1, pp. 12–16, 2007, doi: 10.1002/tee.20109.
- [27] The Environmental Impact of Wasting Electricity, [https://welcome.arcadia.com/energy-101/environmental-impact/the-impact-of-wasted-electricity-on-the-environment \(accessed Mar. 25 2021\)](https://welcome.arcadia.com/energy-101/environmental-impact/the-impact-of-wasted-electricity-on-the-environment (accessed Mar. 25 2021)).
- [28] Top voltage fluctuation causes that you need to know, [https://finolex.com/top-voltage-fluctuation-causes-that-you-need-to-know/ \(Accessed Mar. 25, 2021\)](https://finolex.com/top-voltage-fluctuation-causes-that-you-need-to-know/ (Accessed Mar. 25, 2021)).
- [29] D. Santos and J. C. Ferreira, "IoT power monitoring system for smart environments," *Sustain.*, vol. 11, no. 19, 2019, doi: 10.3390/su11195355.

- [30] L. Zhao, I. Brandao Machado Matsuo, Y. Zhou, and W. J. Lee, "Design of an Industrial IoT-Based Monitoring System for Power Substations," *IEEE Trans. Ind. Appl.*, vol. 55, no. 6, pp. 5666–5674, 2019, doi: 10.1109/TIA.2019.2940668.
- [31] A. Hamied, A. Mellit, M. A. Zoulid, and R. Birouk, "IoT-based experimental prototype for monitoring of photovoltaic arrays," *Proc. 2018 Int. Conf. Appl. Smart Syst. ICASS 2018*, no. November, pp. 1–5, 2019, doi: 10.1109/ICASS.2018.8652014.
- [32] S. Balamurugan and D. Saravanakamalam, "Energy monitoring and management using internet of things," *Int. Conf. Power Embed. Drive Control. ICPEDC 2017*, pp. 208–212, 2017, doi: 10.1109/ICPEDC.2017.8081088.
- [33] Z. H. Che Soh, I. H. Hamzah, S. A. Che Abdullah, M. A. Shafie, S. N. Sulaiman, and K. Daud, "Energy consumption monitoring and alert system via IoT," *Proc. - 2019 Int. Conf. Futur. Internet Things Cloud, FiCloud 2019*, pp. 265–269, 2019, doi: 10.1109/FiCloud.2019.00044.
- [34] W. T. Hartman, A. Hansen, E. Vasquez, S. El-Tawab, and K. Altaï, "Energy monitoring and control using Internet of Things (IoT) system," *2018 Syst. Inf. Eng. Des. Symp. SIEDS 2018*, pp. 13–18, 2018, doi: 10.1109/SIEDS.2018.8374723.
- [35] H. Chaouch, A. S. Bayraktar, and C. Çeken, "Energy Management in Smart Buildings by Using M2M Communication," *7th Int. Istanbul Smart Grids Cities Congr. Fair, ICSG 2019 - Proc.*, pp. 31–35, 2019, doi: 10.1109/SGCF.2019.8782357.